

ELECTROMECHANICAL ROTARY ACTUATORS

GUN/TURRET DRIVES FOR NAVAL SYSTEMS

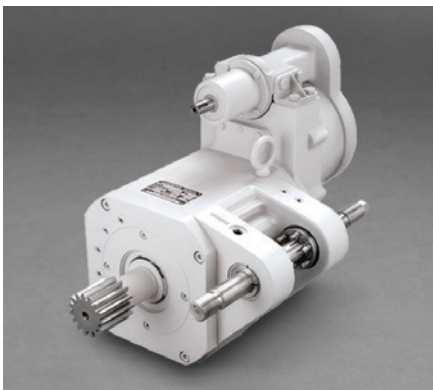

Moog's series of high-torque, direct-drive, brushless motor, rotary actuators is designed for combat turret applications. They meet or exceed the demanding requirements of military environments to include the high-salt content of sea air, while offering world-class weapon pointing, stabilization, and improved slew rates for existing and new weapon turret systems. This series of high-torque motors eliminates the need for a gearbox between the motor and load and provides low-drive inertia for superior stabilization performance and high stiffness with a backlash free coupling. This electromechanical rotary actuator includes an integrated clutch/no-back with a manual drive input.

Moog is a worldwide designer, manufacturer, and integrator of custom precision motion control and stabilization systems for the defense industry. Our electromechanical rotary and linear actuators are ideal for new systems, upgrading from older hydraulic systems, and sustainment service applications.

KEY FEATURES

- Brushless DC motor
- High torque at low rpm allows direct drive
 - Eliminates gearbox
 - Backlash free coupling
 - High stiffness
 - Very low drive inertia for superior stabilization performance
- Integrated 24VDC clutch, no-back and manual drive input (no shift required)
- Adaptable mounting schemes and manual drive configurations
- Complies with MIL-STD 810E / MIL-STD 461E
- Built-in pivot pin with adaptable bushings allows for simple installation and adjustment



Credit: U.S. Navy/Mass Communication Specialist 2nd Class Tim D. Godbee



Credit: U.S. Navy



Credit: U.S. Navy/Chief Mass Communication Specialist Shannon Renfroe

ELECTROMECHANICAL GUN/TURRET DRIVE ACTUATOR

C34R390M



PERFORMANCE

Features	Specifications
Peak torque	910 INLB (103 Nm)
Continuous torque	300 INLB (34 Nm)
No load speed	390 rpm
Rated power	1.25 hp (932W)
Supply voltage	24VDC, 48VDC, 270VDC, or 650VDC
Weight	90 lbs (41 kg)

ARCHITECTURAL AND DIMENSIONAL DRAWING

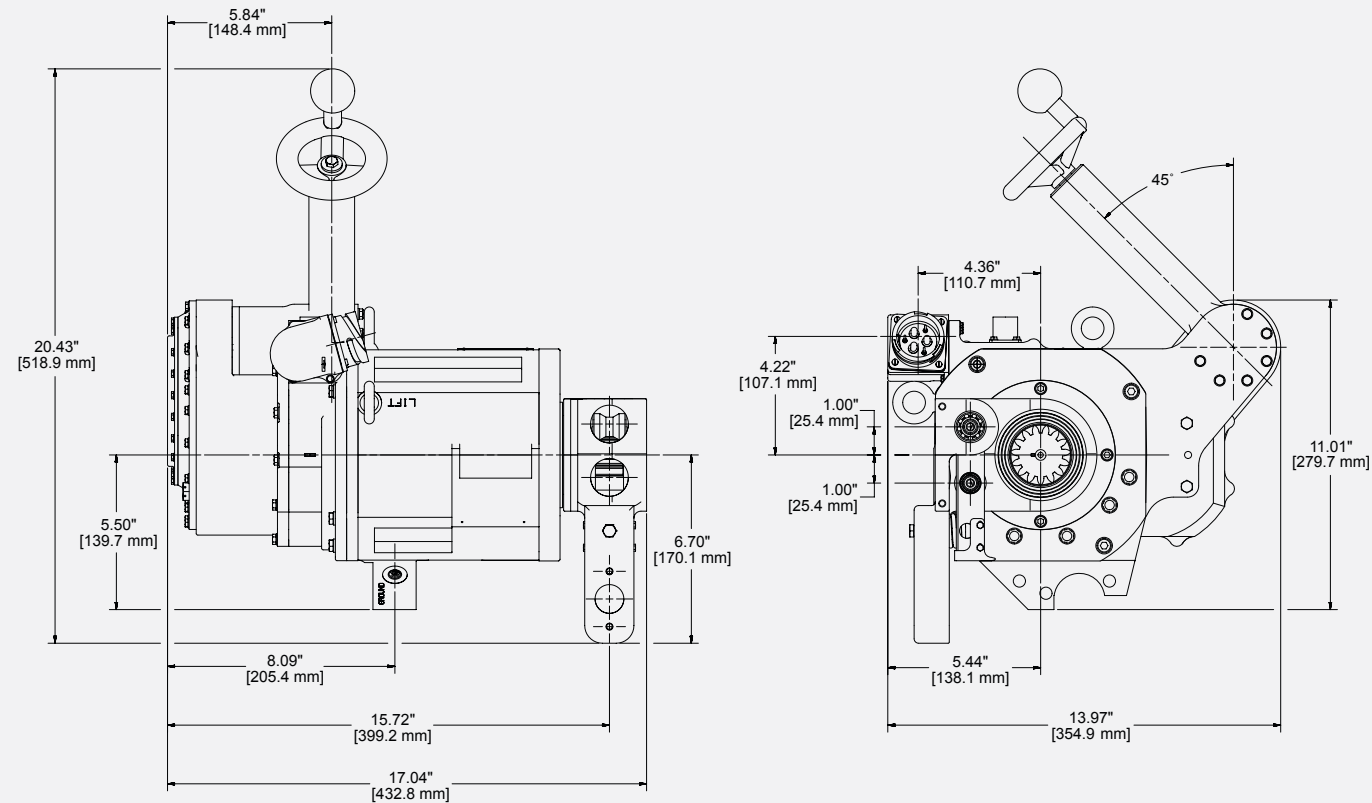

GUN AND TURRET DRIVE ACTUATOR

PERFORMANCE

Features	Specifications
Peak torque	910 INLB (103 Nm)
Continuous torque	300 INLB (34 Nm)
No load speed	390 rpm
Rated power	1.25 hp (932W)
Supply voltage	24VDC, 48VDC, 270VDC, or 650VDC
Weight	90 lbs (41 kg)

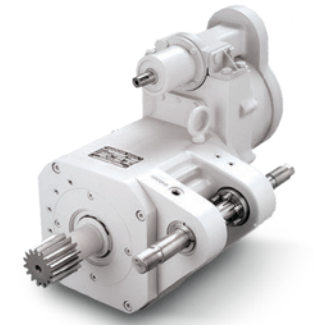

ARCHITECTURAL AND DIMENSIONAL DRAWING

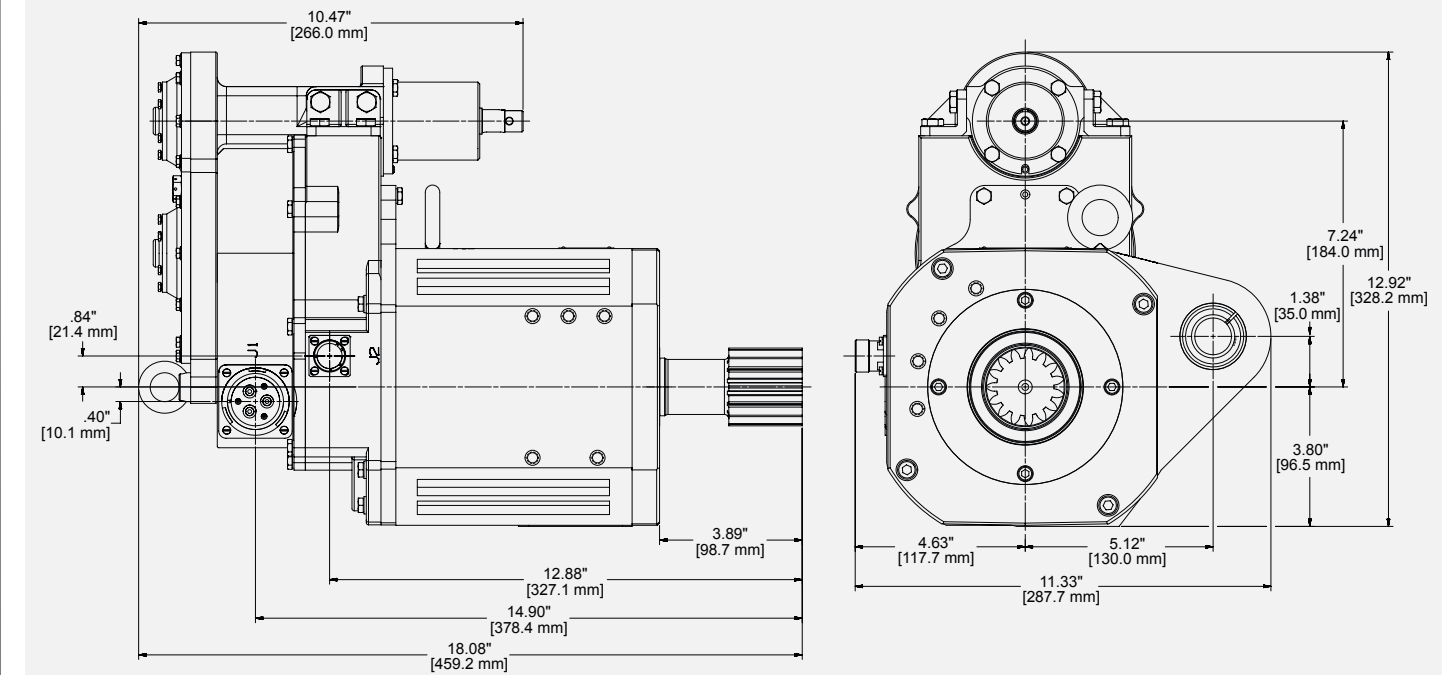

MOOG

SPACE AND DEFENSE GROUP

AMERICAS

navalsystems@moog.com
www.moog.com/defense



Moog Space and Defense

AUSTRALIA

Info.australia@moog.com
www.moog.com.au



Moog Inc.



@Moog_Inc

EUROPE

defenceeurope@moog.com
www.moog.com/defence



@Moog.Inc

The appearance of U.S. Department of Defense (DoD) visual information does not imply or constitute DoD endorsement.

Equipment described herein falls under the jurisdiction of the ITAR and requires US Government Authorization for export purposes. Diversion contrary to US law is prohibited.

©2024 Moog, Inc. All rights reserved.

Product and company names listed are trademarks or trade names of their respective companies.