

## I. INTRODUCTION

This manual provides instructions and procedures necessary to install, operate and troubleshoot the Moog 761K intrinsic safety protected industrial servo valve. The 761K series valves are electrical equipment for hazardous areas requiring intrinsic safety or non-incendive protection. The approved hazardous location markings include:

⊕ II 1G Ex ia IIB/IIC T4 Ga KEMA 02 ATEX1015 X

⊕ II 3G Ex ec II T3 Gc KEMA 02ATEX1016 X

CE 0344 per ATEX directive 2014/34/EU

Ex ia IIB/IIC T4 Ga IECEx KEM 10.0041X

Ex ec IIC T4 Gc IECEx KEM 10.0041X

per IECEx certification scheme.

The G761K servo valves are also approved by FM, CSA, and TIIS for hazardous locations. They are intended for directional, position, velocity, pressure and force control in hydraulic control systems that operate with mineral oil based fluids. Others on request.

## 2. OPERATION

The Moog 761K Series Industrial Servo valve consists of a polarized electrical torque motor and two stages of hydraulic power amplification. The motor armature extends into the air gaps of the magnetic flux circuit and is supported in this position by a flexure tube member. The flexure tube acts as a

seal between the electromagnetic and hydraulic sections of the valve. The two motor coils surround the armature, one on each side of the flexure tube.

The flapper of the first stage hydraulic amplifier is rigidly attached to the midpoint of the armature. The flapper extends through the flexure tube and passes between two nozzles, creating two variable orifices between the nozzle tips and the flapper. The pressure controlled by the flapper and nozzle variable orifice is fed to the end areas of the second stage spool.

The second stage is a conventional 4-way spool design in which output flow from the valve, at a fixed valve pressure drop, is proportional to spool displacement from the null position. A cantilever feedback spring is fixed to the flapper and engages a slot at the center of the spool. Displacement of the spool deflects the feedback spring which creates a force on the armature/flapper assembly.

Input signal induces a magnetic charge in the armature and causes a deflection of the armature and flapper. This assembly pivots about the flexure tube and increases the size of one nozzle orifice and decreases the size of the other.

This action creates a differential pressure from one end of the spool to the other and results in spool displacement. The spool displacement transmits a force in the feedback wire which opposes the original input signal torque. Spool movement continues until the feedback wire force equals the input signal force.

### CAUTION

DISASSEMBLY, MAINTENANCE, OR REPAIR OTHER THAN IN ACCORDANCE WITH THE INSTRUCTIONS HEREIN OR OTHER SPECIFIC WRITTEN DIRECTIONS FROM MOOG WILL INVALIDATE MOOG'S OBLIGATIONS UNDER ITS WARRANTY AND YIELD THE INTRINSICALLY SAFE PROTECTION PERMIT NULL AND VOID.

# MOOG

## 761K Series Installation and Operation Instruction

### Electrohydraulic Servo valve

### Intrinsic Safety Protected



### ELECTROHYDRAULIC VALVE CUT-AWAY

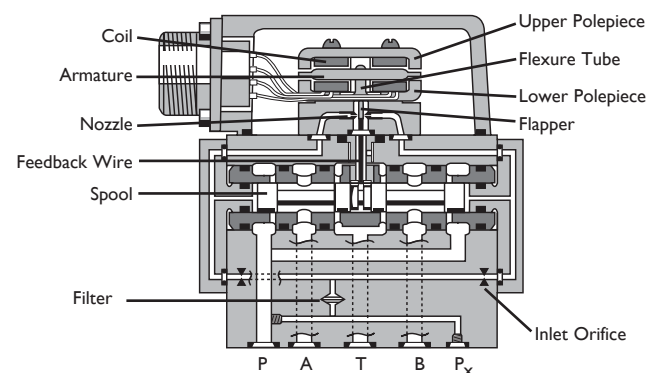

Figure 1

### 3. ELECTRICAL INFORMATION AND INTRINSICALLY SAFE CIRCUIT SAFETY PARAMETERS

- a. A wide choice of coils is available for a variety of rated current requirements. The torque motor coil leads are attached to the connector so external connections can provide series, parallel or single coil operation. The valves are equipped either with an MS type connector or with pigtail leads for electrical wiring. Refer to installation drawings of the specific model for details. Servo valve coils should be driven with current to provide consistency throughout the temperature range.
- b. The 761K valves are approved for intrinsically safe protection per EN IEC 60079-0 : 2018, EN 60079-7 : 2015, and EN 60079-11 : 2012 for ATEX, and IEC 60079-0 : 2017, IEC 60079-7 : 2017, and IEC 60079-11 : 2011 for IECEx. The approved safety parameters are listed in the following table for all the coils used by 761K series. Coil number is marked on the valve nameplate.

Coil Configuration	Marking	U <sub>i</sub> (MAX)	I <sub>i</sub> (MAX)
G4220-031 (single, series, parallel)	Ex ia IIB T4	12 V	120 mA
G4220-051/098 (single, series, parallel)	Ex ia IIB T4	12 V	240 mA
G4221-001 G4220-042 (single)	Ex ia IIC T4	16 V	160 mA
G4221-001 G4220-042 (single)	Ex ia IIC T4	24.4 V	85 mA
G4220-031 (single, parallel)	Ex ia IIC T4	30 V	26 mA
G4220-031 (series)	Ex ia IIC T4	30 V	18 mA
G4220-051/098 (single, parallel)	Ex ia IIC T4	30 V	19 mA
G4220-051/098 (series)	Ex ia IIC T4	30 V	12.7 mA
G4220-042 (single)	Ex ia IIC T4	30 V	37 mA
G4220-042 (parallel)	Ex ia IIC T4	30 V	20 mA
G4220-042 (series)	Ex ia IIC T4	30 V	10 mA
G4221-001 (single)	Ex ia IIC T4	30 V	28 mA

- c. The 761K valves are approved for non-incendive operation for supply current not to exceed 50 mA dc.
- d. When making electric connections to the valve, appropriate measures must be taken to ensure that locally different earth potential do not result in excessive ground currents. When barriers are required for the hazardous location, hazardous area (field) wiring must meet the requirements of the barrier manufacturer. All barriers must be mounted and installed in compliance with the barrier manufacturer's requirements. Twisted pairs of 18-20 gage wire are recommended. If shielded wire is used, connect shield wire to earth ground only at the barrier strip.

### 4. SPECIAL CONDITIONS FOR SAFE USE

Because the enclosure of the apparatus is made of aluminum, if it is mounted in an area where the use of category I G apparatus is required, it must be installed such that even in the event of rare incidents, ignition sources due to impact and friction sparks are excluded.

When the electrohydraulic servo valve is used in an application for type of explosion protection intrinsic safety "i", the appropriate box on the data label must be scored. When the electrohydraulic servo valve is used in an application for type of explosion protection "n", the appropriate box on the data label must be scored.

After use in an application for type of explosion protection "n", the servo valve cannot be safely used in a intrinsically safe application.

The screwed cable connector may only be disconnected when the circuit is de-energized or when the location is known to be non-hazardous.

When used at an ambient temperature  $\geq 70^{\circ}\text{C}$ , heat resistant cable must be used with a continuous operating temperature in accordance with the application. When the electrohydraulic servo valve is used in type of protection "n" or "ec", the equipment shall only be used in an area of not more than Pollution Degree 2, as defined in IEC 60664-1.

The cable gland shall be installed such that impact is not possible.

When the electrohydraulic servo valve is used in type of protection "n" or "ec", the user shall provide additional clamping of the cable to ensure that pulling is not transmitted to the terminations.

### 5. HYDRAULIC SYSTEM PREPARATION

To prolong servo valve operational life and to reduce hydraulic system maintenance, it is recommended that the hydraulic fluid be kept at a cleanliness level of ISO DIS 4406 Code 17/14/11 maximum, 15/13/10 recommended. The most effective filtration scheme incorporates the use of a kidney loop or "off-line" filtration as one of the major filtration components. The filter for the "off-line" filtration scheme should be a  $B_3 \geq 75$  filter for maximum effectiveness.

Upon system startup and prior to mounting the servo valve, the entire hydraulic system should be purged of built-in contaminating particles by an adequate flushing. The servo valve should be replaced by a flushing manifold and the hydraulic circuit powered up under conditions of fluid temperature and fluid velocity, reasonably simulating normal operating conditions. New system filters are installed during the flushing process whenever the pressure drop across the filter element becomes excessive. The flushing processes should turn over the fluid in the reservoir between fifty to one hundred times.

To maintain a clean hydraulic system, the filters must be replaced on a periodic basis. It is best to monitor the pressure drop across the filter assembly and replace the filter element when the pressure drop becomes excessive. In addition to other filters that are installed in the hydraulic circuit, it is recommended that a large capacity, low pressure  $B_3 \geq 75$  filter be installed in the return line. This filter will increase the interval between filter element replacement and greatly reduce the system contamination level.

### 6. INSTALLATION

The Moog 761K series industrial servo valve may be mounted in any position, provided the servo valve pressure, control and tank ports match respective manifold ports.

The mounting pattern and port location of the servo valve is shown on Figure 4. Apply a light film of oil to the screw threads and torque to 96 inch pounds. Wire mating connector for desired coil configuration and polarity. Thread connector to valve.

### 7. NULL ADJUSTMENT

It is often desirable to adjust the hydraulic null of a servo valve independent of other system parameters. The hydraulic null position affects the flow output when there is no signal applied. The standard "mechanical null adjust pin" on the Moog 761K series servo valve allows at least  $\pm 20\%$  adjustment.

The "mechanical null adjuster" is an eccentric bushing retainer pin located above the port 'T' designation on the valve body (see Figure 2). Rotating the null pin adjusts the bushing position, affecting the hydraulic centering of the valve.

A "magnetic null adjuster" is an alternative option, located on top of the motor cap. This option allows at least  $\pm 10\%$  null adjustment. When rotated, it shifts the spool position by adding a magnetic bias to the Torque Motor.

#### Mechanical Adjustment Procedure

Using a 3/8 inch offset box wrench, loosen the self-locking fitting until the null adjuster pin can be rotated. (This should usually be less than 1/2 turn). DO NOT remove self-locking fitting. Insert a 3/32 inch Allen wrench in null adjuster pin. Use the 3/32 Allen wrench to rotate the mechanical null adjuster pin to obtain desired hydraulic null. Torque self-locking fitting to 57 inch lbs.

#### Magnetic Adjustment Procedure

Rotate the hexagonal disc on top of the motor cap to change the center position of the spool. Maximum null adjustment is reached with  $\pm 90^{\circ}$  rotation.

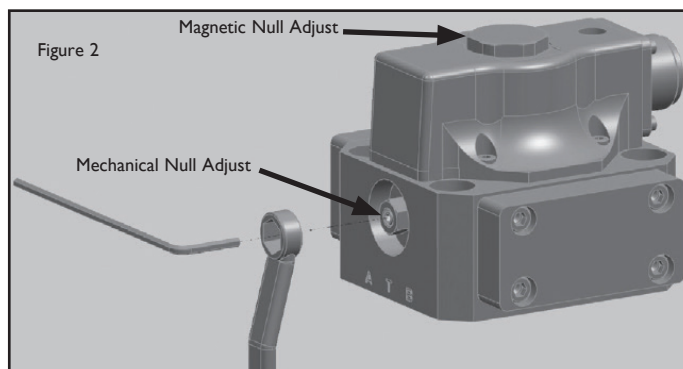

## 8. GENERAL SERVICING RECOMMENDATIONS

- Disconnect the electrical lead to the servo valve.
- Relieve the hydraulic system of residual pressure.
- Remove the servo valve.

## 9. TROUBLESHOOTING CHART

The following troubleshooting chart list potential troubles encountered, probable causes and remedies.

Potential Trouble	Probable Cause	Remedy
Servovalve does not follow input command signal. (Actuator or components are stationary or creeping slowly.)	Plugged inlet filter element.	Replace filter element.
High threshold. (Jerky, possible oscillatory or "hunting" motion in closed loop system.)	Plugged filter element.	Replace filter element.
Poor response. (Servovalve output lags electrical command signal).	Partially plugged filter element.	Replace filter element and check for dirty hydraulic fluid in system.
High Null Bias. (High input current required to maintain hydraulic cylinder or motor stationary.)	1. Incorrect null adjustment 2. Partially plugged filter element.	1. Readjust null 2. Replace filter element and check for dirty hydraulic fluid in system.

Particulate contamination can cause all of the above, including shifting null bias and degraded performance. A valve that is suspected of contamination should be serviced by Moog to be cleaned and re-calibrated.

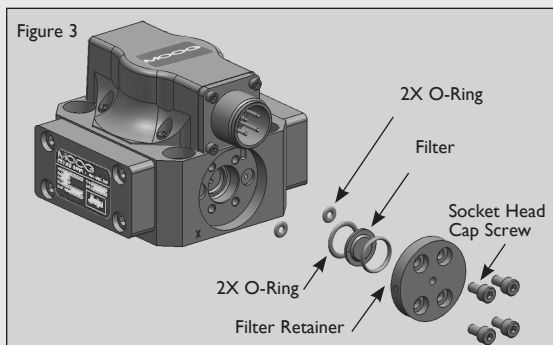

**Table I. Replacement Parts**

Part Description	Part Number
761K Series Maintenance Kit (63 micron)	B52555RK201K001
761K Series Maintenance Kit (28 micron)	B52555RK204K001

## 10. FILTER ASSEMBLY REPLACEMENT

### Tools and Equipment

- 3mm Allen wrench
  - Torque wrench
- Remove the four socket head capscrews and lockwashers with 3mm Allen wrench.
  - Remove the filter retainer.
  - Remove and discard the filter disc.
  - Remove and replace the o-ring on the filter retainer and the o-ring in the filter bore.
  - Reinstall in reverse order, torque screws to 35-40 in-lbs.

## 11. FUNCTIONAL CHECKOUT AND CENTERING

- Install servo valve on hydraulic system or test fixture, but do not connect electrical lead.
- Apply required system pressure to servo valve and visually examine for evidence of external leakage. If leakage is present and cannot be rectified by replacing o-rings, remove the discrepant component and return for repair or replacement.  
Note: If the system components are drifting or hardover, adjust the hydraulic null as described in section 7.
- Connect electrical lead to servo valve and check phasing in accordance with system requirements.

## 12. AUTHORIZED REPAIR FACILITIES

If servo valve continues to malfunction after all recommended corrective action procedures are performed, defective valve should be returned to Moog for repair. Moog does not authorize any facilities other than Moog or Moog subsidiaries to repair its servo valves. It is recommended you contact Moog at (716) 652-2000 to locate your closest Moog repair facility. Repair by an independent (unauthorized) repair house will result in voiding the Moog warranty and could lead to performance degradation or safety problems.

## 13. DECLARATION OF MANUFACTURER

An EU Declaration of Conformity according to Council Directive 2014/34/EU is supplied with each servo valve.

## 14. ROUTINE MAINTENANCE GUIDELINES

Every six months or 4,000 operating hours, check for proper operation of the control valve assembly by performing the preventative maintenance steps outlined below. These checks do not require removal of the valve from the process line. If a problem is suspected, repair the valve assembly prior to returning the unit to service.

- Replace the hydraulic filter element
- Stroke the valve and check for smooth, full-stroke operation; unsteady motion could indicate a servo valve, actuator or process valve problem

### General Information

#### Effects when Storing Valves

The following effects may occur when storing valves for a long time:

- Sealing materials become brittle, possibly resulting in leaks
- Hydraulic fluid becomes gummy, possibly resulting in friction

#### Storage Time

The storage time starts at stock receipt and ends at mounting of the valve.

#### Preservatives

If preservation is carried out, use only preservatives which are compatible with the sealing materials and do not affect the valve, spare parts and accessories.

### Before Storage

Note: If the valves are exposed to aggressive environmental influences during storage, vacuum packaging may be necessary.

We recommend the following preparatory measures for storage:

#### Mount the shipping plate on the valve.

This is the only way of adequately protecting the valves against the ingress of dirt and moisture and protecting the seals against the effects of ozone and UV.

#### Put the valve, spare parts and accessories into the original packaging.

Package each valve separately.

#### Enclose anti-tarnish paper or package the valve, spare parts and accessories with corrosion inhibiting film.

(Only for storage time > 1 year.)

Multipacks of single valves in their individual packages are allowed.

#### Seal the original packaging properly.

This is the only way of adequately protecting the valves, spare parts and accessories against damage.

### Storage Conditions

We recommend the following ambient conditions for storage:

- Dust-free, moderately ventilated
- As vibration-free and shock-free as possible

Shock resistance (as per EN 60068-2-27):

50g, 6 directions, half-sine 3ms

Vibration resistance (as per EN 60068-2-6):

30g, 3 axes, frequency 10 to 2,000 Hz

#### Temperature

Recommended: +15 to +25°C (+59 to +77°F)

Permissible: -40 to +60°C (-40 to +140°F)

Temperature fluctuations >10°C (50°F) must be avoided.

Distance to shielded radiators: > 1m (3ft).

No direct exposure to sunlight.

No sources of light with a high UV content.

UV rays generate ozone, which damage sealing materials.

Relative air humidity: < 65%, non condensing

### After Storage

We recommend to check the original packaging, valve, spare parts and accessories for possible damage or alterations due to storage, that is, before use.

Damaged or not functional valves, spare parts and accessories must not be started up.

Sealing materials with the following characteristics must not be used:

- Contamination
- Cracking
- Hardening/softening
- Stickiness
- Discoloration

#### Storage Time > 5 Years

We recommend that the valve be checked by us or one of our authorized service centers after a storage time of more than 5 years.

#### Storage Time > 10 Years

After a storage time of more than 10 years the valves have to be checked by us or one of our authorized service centers.

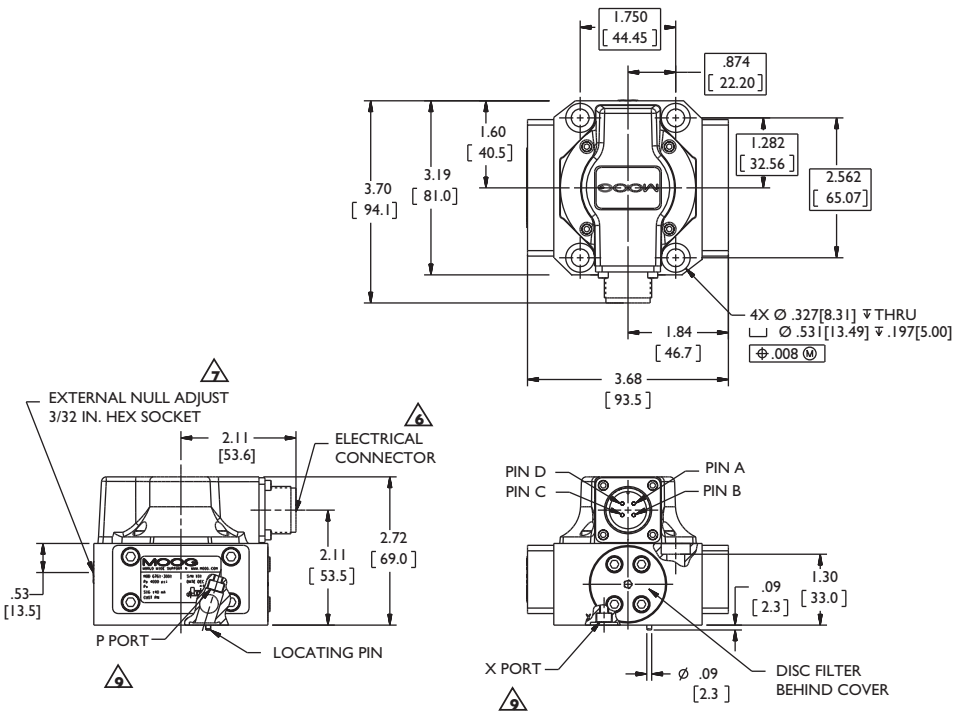

**Recommended Mounting Seals**

Material dependant on application

- 1.78 mm (0.070 in) cross-section x 10.82 mm (0.426 in) inside diameter, 90 durometer. Equivalent AS83248/2 size -013 for P, A, B, and T ports
- 1.78 mm (0.070 in) cross-section x 9.25 mm (0.364 in) inside diameter, 90 durometer. Equivalent AS83248/2 size -012 for X port

**Recommended Mounting Screws**

Material dependant on application

- SHCS 5/16 x 1.75 long. Grade 8 minimum
- SHCS M8 x 45 long. Grade 10.9 minimum

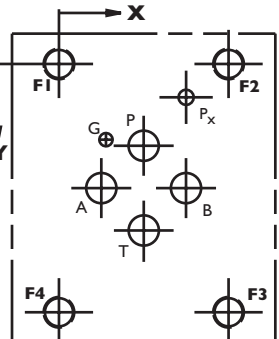

Figure 4

U.S.	P	A	B	T	X	G	F1	F2	F3	F4
	Ø.32	Ø.32	Ø.32	Ø.32	Ø.2	Ø.14	5/16-18	5/16-18	5/16-18	5/16-18
<b>X</b>	0.87	0.44	1.31	0.87	1.31	0.48	0	1.75	1.75	0
<b>Y</b>	0.84	1.28	1.28	1.72	0.34	0.78	0	0	2.56	2.56

METRIC	P	A	B	T	X	G	F1	F2	F3	F4
	Ø8.2	Ø8.2	Ø8.2	Ø8.2	Ø5.0	Ø3.5	M8	M8	M8	M8
<b>X</b>	22.2	11.1	33.3	22.2	33.3	12.3	0	44.4	44.4	0
<b>Y</b>	21.4	32.5	32.5	43.6	8.7	19.8	0	0	65.0	65.0

**CONVERSION INSTRUCTION**

For operation with internal or external pilot connection.	Pilot flow supply	Location of M4 x 8 DIN912 socket head cap screw and seal washer	
		<b>X</b>	<b>P</b>
Internal P		closed	open
External X		open	closed

The products described herein are subject to change at any time without notice, including, but not limited to, product features, specifications, and designs.

**NOTES**

**1 Fluid:**  
Industrial type petroleum base hydraulic fluid, maintained to ISO DIS 4406 Code 15/13/10 recommended.

**2 Operating Temperature Range:**  
-20°F [-29°C] to +275°F [+135°C] unless otherwise specified on nameplate.

**3 Valve Phasing:**  
Flow out port B results when Series coils: B & C connected, A+, D-; Parallel coils: A & C connected, B & D connected; Single coil: A+, B-, or C+, D-.

**4 Manifold O-Rings**  
0.070 (1.78) sect x 0.426 (10.82) I.D. (Universal dash No. 13) for P, A, B, T port  
0.070 (1.78) sect x 0.364 (9.25) I.D. (Universal dash No. 12) for X port

**5 Surface:**  
Surface to which valve is mounted requires  $\sqrt{32}$  finish, flat within .001 [0.03] TIR

**6 Electrical Connector:**  
Mates with MS3106F14S-2S or equivalent

**7 Null Adjust:**  
Flow out of port B will increase with clockwise rotations of null adjust (3/32 hex key). Flow bias is continually varied for a given port as the null adjust is rotated.

**8 Compressed Oil Volume**  
for one control port: 0.229 in<sup>3</sup> (3.75 cm<sup>3</sup>)

**9 M3 Internal Hex**

Dimensions in parenthesis are in millimeters.

**TYPICAL WIRING SCHEMATIC**

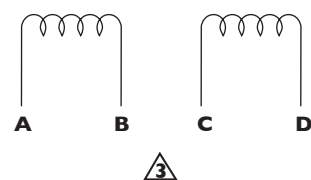

**CERTIFICATION CONTROLLED RELATED DOCUMENT**  
THIS INSTALLATION INSTRUCTION IS CERTIFICATION CONTROLLED. REVISION SHALL BE APPROVED BY THE MOOG ICD EX/ATEX AUTHORIZED PERSON AND MAY REQUIRE APPROVAL BY THE ATEX NOTIFIED BODY.  
APPLICABLE CERTIFICATE(S):  
KEMA 02ATEX1015 X  
KEMA 02ATEX1016 X

**MOOG**  
Industrial Controls Division  
Moog Inc., East Aurora, NY 14052-0018  
Telephone: 716/652-2000  
Fax: 716/687-7910  
Toll Free: 1-800-272-MOOG  
www.moog.com

TJW, Rev. G, May 2024, CDS6769