

VIKING SERIES

10/100/1000BASE-T/SX, AUTO MDI/MDIX, AUTONEGOTIABLE
MIL-DTL-38999, MANAGED ETHERNET SWITCH



Viking series 10/100/1000Base-T/SX managed Ethernet switches consist of 4x10/100/1000Base-T ports plus 2x1000Base-SX port in a wall or floor mounted in-line MIL-DTL-38999 connector assembly.

The Viking series Ethernet switch offers two separate D38999 Ethernet connector interfaces. One interface is a D38999/19-35 with 4x10/100/1000 Base-T Ethernet ports compliant with IEEE-802.3:2005 plus the 28 VDC interface. The other interface is a D38999/19-11 with 2x1000Base-SX Ethernet fiber optic ports per IEEE-802.3:2005.

The Viking 4+2 port Ethernet switch is a highly integrated and extremely rugged solution for vehicle and mobile networking applications. Its small size, light weight and low power requirements make it an excellent fit for next generation networks.

Viking series 10/100/1000Base-T/SX Ethernet switches are vibration isolated, environmentally hardened components designed for use in harsh environment applications.

SIX PORT (4+2) VIKING SERIES D38999, 10/100/1000BASE-T/SX MANAGED ETHERNET SWITCH

D38999 In-line 4+2 Port 10/100/1000Base-T/SX Ethernet Switch
6 Port (4 + 2), Jam Nut Mounted

FEATURES

- 4x10/100/1000Base-T nonblocking wire speed copper Ethernet ports per IEEE 802.3:2005
- 2x1000Base-SX fiber Ethernet ports per IEEE 802.3:2005
- Electrical cable links up to 100 meters (EIA/TIA Cat-5E)
- Fiber optic link distances up to 550 meters per IEEE 802.3
- Operating temperature range from -40°C to +85°C
- Jumbo frame support in all speeds (10/100/1000 Mbps)
- Full duplex flow control per IEEE Std 802.3x and half duplex back pressure, symmetric and asymmetric
- OD-CD, NI or ZN-NI plating options for enhanced corrosion resistance
- Aluminum connector shells and housing are strong, durable and light weight
- Auto sensing of half or full duplex operation

APPLICATIONS

Viking series 4+2 port Ethernet switches enable high speed network communications in harsh environments.

- Civil and military vehicle networking
- Aerospace and naval platform networks
- Managed Ethernet switch applications

The MIL-DTL-38999, series III connectors provide a sealed interface that is water-tight to MIL-STD-810 when mated.

ORDERING INFORMATION

Application	Part Number
10/100/1000BASE-T/SX - 28 VDC	VM42J-6SET-FW

See Appendix A2 for more part number options

SIX PORT (4+2) VIKING SERIES D38999, 10/100/1000BASE-T/SX MANAGED ETHERNET SWITCH

ABSOLUTE MAXIMUM RATINGS

Absolute maximum limits mean that no catastrophic damage will occur if the product is subjected to these ratings for short periods, provided each limiting parameter is in isolation and all other parameters have values within the performance specification. It should not be assumed that limiting values of more than one parameter can be applied to the product at the same time.

Parameter	Symbol	Minimum	Typical	Maximum	Unit
Storage Temperature	T_s	-55		+100	°C

RECOMMENDED OPERATING CONDITIONS

Parameter	Symbol	Minimum	Typical	Maximum	Unit
Operating Temperature	T_A	-40		+85	°C
Supply Voltage	V_{CC}	+18	+28	+36	V
Power Supply Noise (p-p)	N_p			200	mV

DESIGNED TO SPECIFICATIONS

Requirement	Description	Section
MIL-STD-461	Conducted Emissions	CE102
MIL-STD-461	Conducted Susceptibility	CS101, CS114-116
MIL-STD-461	Radiated Emissions	RE102
MIL-STD-461	Radiated Susceptibility	RS103
MIL-STD-810	High/Low Temp Opp	M 501.6 / 502.6 P II
MIL-STD-810	High/Low Temp Storage	M 502.6 / 502.6 P I
MIL-STD-810	Altitude Opp / Non-Opp	M 500 P I, 15k feet
MIL-STD-810	Humidity	M 507, P II
MIL-STD-810	Acoustic Noise	M 515.7 P I
MIL-STD-810	Shock	> 100G
MIL-STD-810	Vibration	M 514
MIL-STD-810	Sea Salt Atmosphere	M 509
MIL-STD-810	Fungus	M 508.6
ANSI/ESD S20.20	ESD	Class 1
MIL-STD-704	Steady State Limits for Voltage	LDC102
MIL-STD-704	Voltage Distortion Spectrum	LDC103
MIL-STD-704	Total Ripple	LDC104
MIL-STD-704	Steady State Limits	LDC301

MATERIALS

Item	Detail	Notes
Shell and housing	Aluminum Alloy	
Plating	OD-CD, NI or ZN-NI	
Insert	Thermoplastic	
Interfacial Seal	Elastomer	
Alignment Sleeve	Composite Polymer	
Weight	<14 oz / 397 gm	

SIX PORT (4+2) VIKING SERIES D38999, 10/100/1000BASE-T/SX MANAGED ETHERNET SWITCH

TRANSMITTERS T_A = OPERATING TEMPERATURE RANGE

Parameter	Symbol	Minimum	Typical	Maximum	Unit
Optical Output Power	P_o	-9.5		-4.0	dBm
Optical Output Wavelength	λ_{OUT}	830	850	860	nM
Spectral Width	$\Delta\lambda_{RMS}$			0.85	nM

RECEIVERS T_A = OPERATING TEMPERATURE RANGE

Parameter	Symbol	Minimum	Typical	Maximum	Unit
Optical Sensitivity	P_i	-17.0		-2.0	dBm
Optical Wavelength	λ_{IN}	830	850	860	nM

POWER SUPPLY CURRENT T_A = OPERATING TEMPERATURE RANGE

Parameter	Symbol	Minimum	Typical	Maximum	Unit
Supply Current per Port @ 28VDC	I_{CCT}		165	200	mA

OPTICAL FIBER LINK DISTANCES

Application	Cable Specification	Distance
Gigabit Ethernet - IEEE 802.3:2005 - 1000BASE-SX	62.5/125 μ - 200MHz*Km	275M
	50/125 μ - 500MHz*Km	550M

COPPER CABLE LINK DISTANCES

Application	Cable Specification	Distance
Gigabit Ethernet - IEEE 802.3:2005 - 1000BASE-T	TIA/EIA-568-B Cat 5E - for other transmission media, please consult the factory	100M

* for other transmission media, please consult the factory

SIX PORT (4+2) VIKING SERIES D38999, 10/100/1000BASE-T/SX MANAGED ETHERNET SWITCH

OUTLINE DRAWING

Dimensions are shown as: inches [mm]

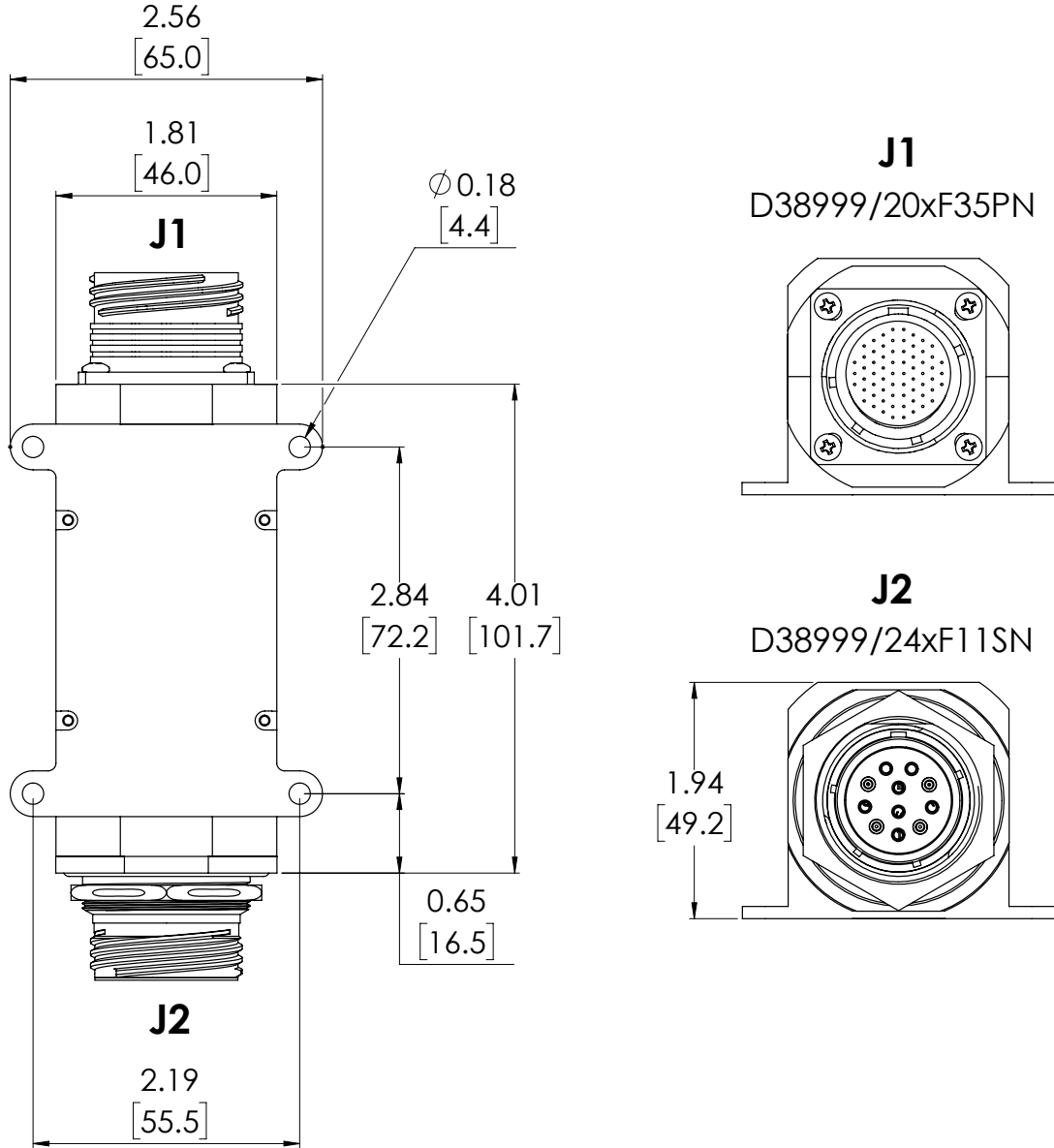

PORT / FUNCTION ASSIGNMENTS

Port Number	Function
J1	4x10/100/1000Base-T + 28 VDC
J2	2x1000Base-SX

SIX PORT (4+2) VIKING SERIES D38999, 10/100/1000BASE-T/SX MANAGED ETHERNET SWITCH

J1 PIN FUNCTIONS ETHERNET PORT AND PIN ASSIGNMENTS TOP

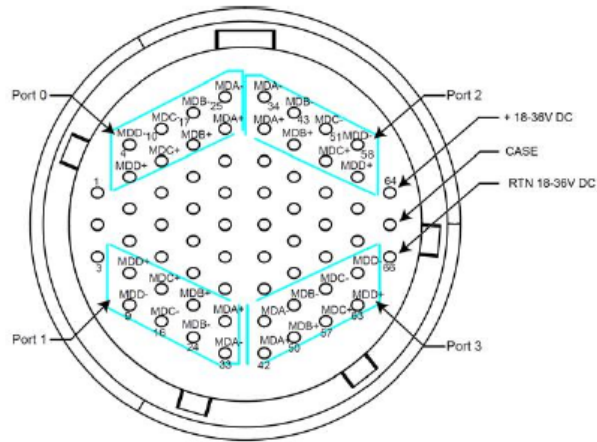

Front view of the J1 connector shown - mating cable plug opposite - see J1 D38999 Pin Function Chart for details

MIL-DTL-38999 OPTICAL INTERFACE					
Port Number	Pin Number	Function	Port Number	Pin Number	Function
0	26	MDA+	2	35	MDA+
	25	MDA-		34	MDA-
	18	MDB+		44	MDB+
	17	MDB-		43	MDB-
	11	MDC+		52	MDC+
	10	MDC-		51	MDC-
	5	MDD+		59	MDD+
	4	MDD-		58	MDD-
1	32	MDA+	3	42	MDA+
	33	MDA-		41	MDA-
	23	MDB+		50	MDB+
	24	MDB-		49	MDB-
	15	MDC+		57	MDC+
	16	MDC-		56	MDC-
	8	MDD+		63	MDD+
	9	MDD-		62	MDD-

SIX PORT (4+2) VIKING SERIES D38999, 10/100/1000BASE-T/SX MANAGED ETHERNET SWITCH

J1 / D38999/20XF35PN ELECTRICAL PIN FUNCTIONS - CONTINUED ON NEXT PAGE

Pin Number	Port Number	Function	RJ-45 Eq. Pin Number	Logic Family
1	N/A	N/C	N/A	Do Not Connect - Factory Use Only
2	N/A	N/C	N/A	Do Not Connect - Factory Use Only
3	N/A	N/C	N/A	Do Not Connect - Factory Use Only
4	0	MDD-	8	IEEE-802.3.2005 10/100/1000Base-T
5	0	MDD+	7	IEEE-802.3.2005 10/100/1000Base-T
6	N/A	N/C	N/A	Do Not Connect - Factory Use Only
7	N/A	N/C	N/A	Do Not Connect - Factory Use Only
8	1	MDD+	7	IEEE-802.3.2005 10/100/1000Base-T
9	1	MDD-	8	IEEE-802.3.2005 10/100/1000Base-T
10	0	MDC-	5	IEEE-802.3.2005 10/100/1000Base-T
11	0	MDC+	4	IEEE-802.3.2005 10/100/1000Base-T
12	N/A	N/C	N/A	Do Not Connect - Factory Use Only
13	N/A	N/C	N/A	Do Not Connect - Factory Use Only
14	N/A	N/C	N/A	Do Not Connect - Factory Use Only
15	1	MDC+	4	IEEE-802.3.2005 10/100/1000Base-T
16	1	MDC-	5	IEEE-802.3.2005 10/100/1000Base-T
17	0	MDB-	6	IEEE-802.3.2005 10/100/1000Base-T
18	0	MDB+	3	IEEE-802.3.2005 10/100/1000Base-T
19	N/A	N/C	N/A	Do Not Connect - Factory Use Only
20	N/A	N/C	N/A	Do Not Connect - Factory Use Only
21	N/A	N/C	N/A	Do Not Connect - Factory Use Only
22	N/A	N/C	N/A	Do Not Connect - Factory Use Only
23	1	MDB+	6	IEEE-802.3.2005 10/100/1000Base-T
24	1	MDB-	3	IEEE-802.3.2005 10/100/1000Base-T
25	0	MDA-	2	IEEE-802.3.2005 10/100/1000Base-T
26	0	MDA+	1	IEEE-802.3.2005 10/100/1000Base-T
27	N/A	N/C	N/A	Do Not Connect - Factory Use Only
28	N/A	N/C	N/A	Do Not Connect - Factory Use Only
29	N/A	N/C	N/A	Do Not Connect - Factory Use Only
30	N/A	N/C	N/A	Do Not Connect - Factory Use Only
31	N/A	N/C	N/A	Do Not Connect - Factory Use Only
32	1	MDA+	1	IEEE-802.3.2005 10/100/1000Base-T
33	1	MDA-	2	IEEE-802.3.2005 10/100/1000Base-T
34	2	MDA-	2	IEEE-802.3.2005 10/100/1000Base-T

SIX PORT (4+2) VIKING SERIES D38999, 10/100/1000BASE-T/SX MANAGED ETHERNET SWITCH

J1/D38999/20XF35PN ELECTRICAL PIN FUNCTIONS - CONTINUED FROM PREVIOUS PAGE

Pin Number	Port Number	Function	RJ-45 Eq. Pin Number	Logic Family
35	2	MDA+	1	IEEE-802.3.2005 10/100/1000Base-T
36	N/A	N/C	N/A	Do Not Connect - Factory Use Only
37	N/A	N/C	N/A	Do Not Connect - Factory Use Only
38	N/A	N/C	N/A	Do Not Connect - Factory Use Only
39	N/A	N/C	N/A	Do Not Connect - Factory Use Only
40	N/A	N/C	N/A	Do Not Connect - Factory Use Only
41	3	MDA-	2	IEEE-802.3.2005 10/100/1000Base-T
42	3	MDA+	1	IEEE-802.3.2005 10/100/1000Base-T
43	2	MDB-	6	IEEE-802.3.2005 10/100/1000Base-T
44	2	MDB+	3	IEEE-802.3.2005 10/100/1000Base-T
45	N/A	N/C	N/A	Do Not Connect - Factory Use Only
46	N/A	N/C	N/A	Do Not Connect - Factory Use Only
47	N/A	N/C	N/A	Do Not Connect - Factory Use Only
48	N/A	N/C	N/A	Do Not Connect - Factory Use Only
49	3	MDB-	6	IEEE-802.3.2005 10/100/1000Base-T
50	3	MDB+	3	IEEE-802.3.2005 10/100/1000Base-T
51	2	MDC-	5	IEEE-802.3.2005 10/100/1000Base-T
52	2	MDC+	4	IEEE-802.3.2005 10/100/1000Base-T
53	N/A	N/C	N/A	Do Not Connect - Factory Use Only
54	N/A	N/C	N/A	Do Not Connect - Factory Use Only
55	N/A	N/C	N/A	Do Not Connect - Factory Use Only
56	3	MDC-	5	IEEE-802.3.2005 10/100/1000Base-T
57	3	MDC+	4	IEEE-802.3.2005 10/100/1000Base-T
58	2	MDD-	8	IEEE-802.3.2005 10/100/1000Base-T
59	2	MDD+	7	IEEE-802.3.2005 10/100/1000Base-T
60	N/A	N/C	N/A	Do Not Connect - Factory Use Only
61	N/A	N/C	N/A	Do Not Connect - Factory Use Only
62	3	MDD-	8	IEEE-802.3.2005 10/100/1000Base-T
63	3	MDD+	7	IEEE-802.3.2005 10/100/1000Base-T
64	ALL	V _{CC}	N/A	18-36VDC
65	ALL	N/C	N/A	Do Not Connect - Factory Use Only
66	ALL	N/C	N/A	Isolated from Case GND

SIX PORT (4+2) VIKING SERIES D38999, 10/100/1000BASE-T/SX MANAGED ETHERNET SWITCH

J2 PIN FUNCTIONS ETHERNET PORT AND PIN ASSIGNMENTS TOP

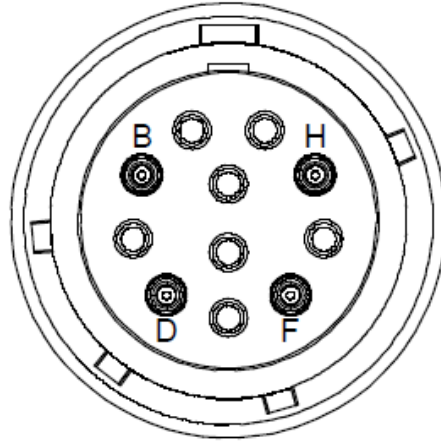

Front view of the D38999 optical insert shown, fiber optic cable plug opposite - see Appendix A1 for details

MIL-DTL-38999 OPTICAL INTERFACE		
Port Number	TX	RX
4	H	F
5	B	D

SIX PORT (4+2) VIKING SERIES D38999, 10/100/1000BASE-T/SX MANAGED ETHERNET SWITCH

ETHERNET SWITCH MANAGEMENT FEATURES WEB-BASED GUI FOR CONFIGURATION	
Layer	Features
1	Cable Diagnostic
	Cascading
	EEE Power Saving (IEEE 802.3az)
	AVS
	Link Aggregation
2	Jumbo Frame Support
	Switching/MAC Learning
	Broadcast Storm Control
	VLAN Support (Multiple Bridging Domains)
	Isolation Group (Tree)
	AutoVoIP
	AutoDOS
2 QoS	8 Queues Per Port
	IEEE 802.1p Priority Mapping
	DSCP Priority Mapping
	Scheduling Configurable SP
	Scheduling Configurable WRR
	Metering Rate Limiting
	Shaping Queue/Port
	Flow Control – PAUSE IEEE 802.3x
	Flow Control – PFC IEEE 802.
Management	Debug CLI
	RESTful API
	Rx and Tx Counters
Multicast	IGMP Snooping
Protocols and Advanced	LLDP
	Rapid Spanning Tree

SIX PORT (4+2) VIKING SERIES D38999, 10/100/1000BASE-T/SX MANAGED ETHERNET SWITCH

APPENDIX A1 MIL-DTL-38999 FIBER OPTIC CABLE PLUG/MIL-T-29504 PIN TERMINI

*See DSCC or SAE QPL for Approved Suppliers

<http://www.dscclia.mil/programs/qmlqpl/QPLdetail.asp?QPL=38999>

*D38999 PLUG - RECEPTACLE INSERT

MIL-DTL-38999 Cable Plug

MS PLUG P/N	*D38999 / 26WF11PN
-------------	--------------------

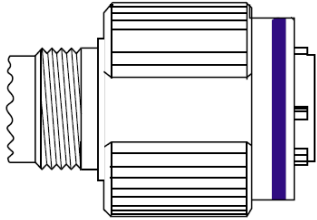

*FIBER OPTIC PIN TERMINUS

MIL-T-29504 Pin Terminus

MS PIN TERMINUS P/N	*M29504 / 04-xxxx**
---------------------	---------------------

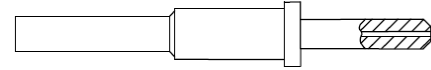

**Defined by fiber optic cable configuration

*CABLE PROTECTION CAP

D38999 / 32 Plug Protection Cap

MS PLUG CAP P/N	*D38999 / 32W19N
-----------------	------------------

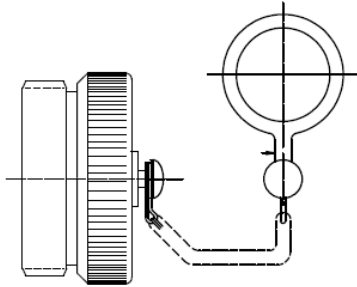

D38999 PLUG PORT FUNCTIONS

Port Number	TX	RX
4	H	F

TOP Optical Cable Plug Interface

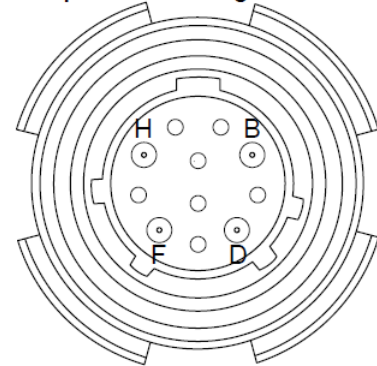

Front face of the optical cable plug pin insert shown. Transceiver insert opposite.

Pin Termini

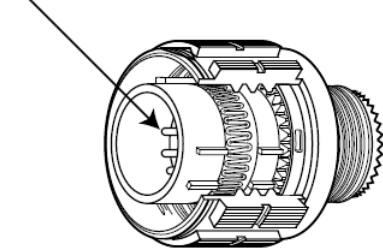

*CABLE BACKSHELL

MIL-C-85049 Cable Backshell

MS BACKSHELL P/N	*MS85049 / xxxxxx**
------------------	---------------------

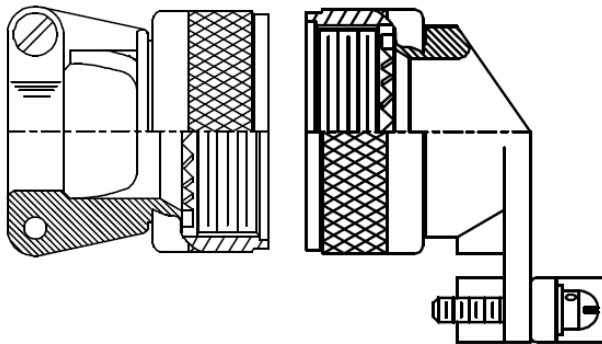

**Straight or angled backshell - defined by application / mounting configuration

SIX PORT (4+2) VIKING SERIES D38999, 10/100/1000BASE-T/SX MANAGED ETHERNET SWITCH

APPENDIX A2 PART NUMBER OPTIONS

In-Line, Six (4+2) Port, 10/100/1000Base-T/SX, Managed Ethernet Switch

VM42 J - 6SET - Fx

Product Function

VM42 = In-line Managed
Ethernet Switch

Shell Configuration

J = Jam Nut

of Ports

6 = 4 + 2

CABLE

S = 1000Base-SX

Power Supply Voltage

E = EMI Filtered 28.0 VDC

Electrical Interface

T = 10/100/1000Base-T

D38999 Shell Size

F = 19-35/11

Shell Planting

F = NI

W = OD CD/NI

Z = ZN/NI

MOOG
PROTOKRAFT

192 Bob Fitz Road, Johnson City, TN 37615

salesmp@moog.com

moogprotokraft.com

Products and solutions are subject to the export control requirements of the country in which they are manufactured and / or sold.

© 2024 Moog, Inc. All rights reserved.

Product and company names listed are trademarks or trade names of their respective companies.

VM42J-6SET-FW, Form DS588, Rev A, October 23, 2024