

651 Series Proportional Valves

SPECIFICATIONS

Fluid Supply: 651 Series proportional valves are intended to operate with constant supply pressure.

Supply Pressure:
Main stage: 5,000 psi (350 bar)
max.* Pilot stage: 200 to 3,000 psi (15 to 210 bar)

Proof Pressure:
150% of supply pressure at P port
2,000 psi (140 bar) maximum at R port

Fluid:
Compatible with common hydraulic fluids
Recommended viscosity range:
60-450 SUS @ 100°F
(10-97 cSt @ 38°C)

Cleanliness Level:
ISO DIS 4406 code 16/13 max.
14/11 recommended

Operating Temperature:
-4°F to 175°F (-2°C to 80°C)

Rated Flows:
(at 150 psi drop per land)
23 cis 3-way
35 cis 3-way
140 cis 5-way & 2 X 2

Rated Flow Tolerance: ±10%

Flow Function	Pressure Function
---------------	-------------------

Linearity: — < 1.0%q

Hysteresis: < 1.0% < 0.2%

Threshold: < 0.25% < 0.05%

Null Shift: < 1.5% < 1.5%

with temperature, 100°F variation

Null Leakage:

< 1.2 gpm (4.5 lpm) @ 2,000 psi

Frequency Response:* Typical spool position responses shown in Figure 1.

Step Response: Typical transient responses are shown in Figure 2.

Step Response:

Typical transient responses are shown in Figure 2.

q₁ < 0.25% available with use of high performance transducer

* may be limited by pressure transducer rating

The 651 Series Proportional Valves are two-stage devices consisting of a double nozzle-flapper pilot stage and a sliding spool main stage. These valves are two-function valves which can be used to control both flow rate and pressure precisely and rapidly. This is achieved through integrated electronics for position control of the sliding spool and integrated electronics with a pressure sensor for pressure control.

The design features of these valves include: integral drive electronics to simplify installation and setup; an international mounting pattern conforming to ISO 4401 form A10 (CETOP 5); a field-replaceable pilot supply filter for improved reliability; provision for either internal (port "P") or external (port "X") pilot supply.

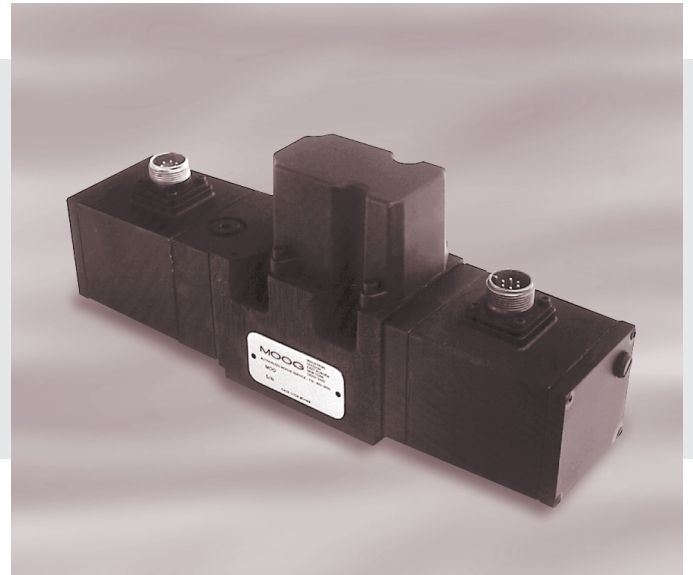

HYDRAULIC SCHEMATIC

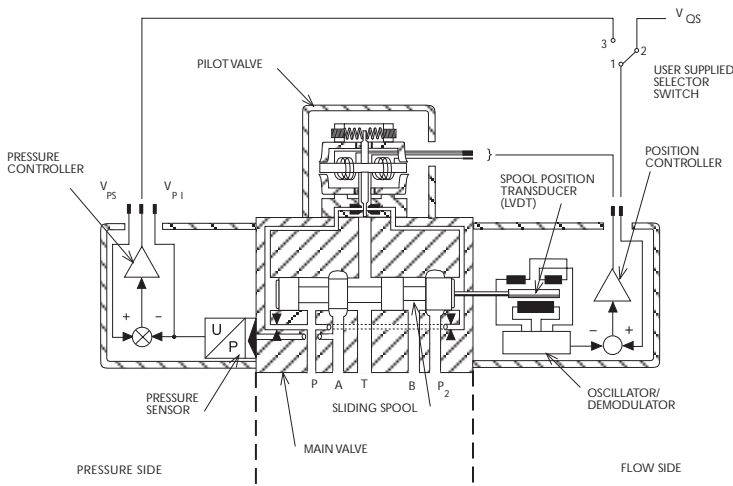

FREQUENCY RESPONSE (Spool position)

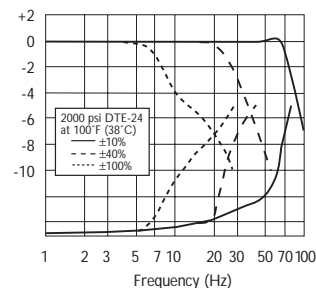

Figure 1

STEP RESPONSE (Spool position)

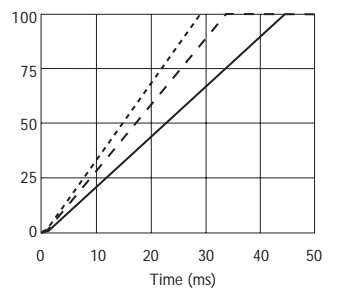

Figure 2

FUNCTIONAL CHARACTERISTICS

(Dependent upon valve model – consult the factory for specific model characteristics)

Flow function:

(Selector switch set to 1-2)

The position of the sliding spool is measured by a position transducer and compared to the command voltage. If the actual value differs from the setpoint, the position controller drives current through the coils of the pilot valve until the difference is reduced to zero. Thus, displacement of the sliding spool from the center position is proportional to the electrical command.

Pressure Function:

Pressure control

(Selector switch set to 1-3)

The load pressure through port A is measured by the built-in pressure sensor and compared with the pressure command voltage. If the actual value differs from the setpoint, the pressure controller changes the spool position command, thus, the valve flow until the difference is reduced to zero.

Flow control with superimposed pressure limiting control

If, due to changes in load, the actual pressure value becomes greater than the pressure command voltage, the pressure limiting controller will override the flow rate control system and reduce the load velocity such that the actual pressure value is limited to the pressure setpoint. Pressure limiting control is only effective if a corresponding flow rate setpoint is applied.

FLOW CONTROL – WITH CHANGE TO PRESSURE CONTROL

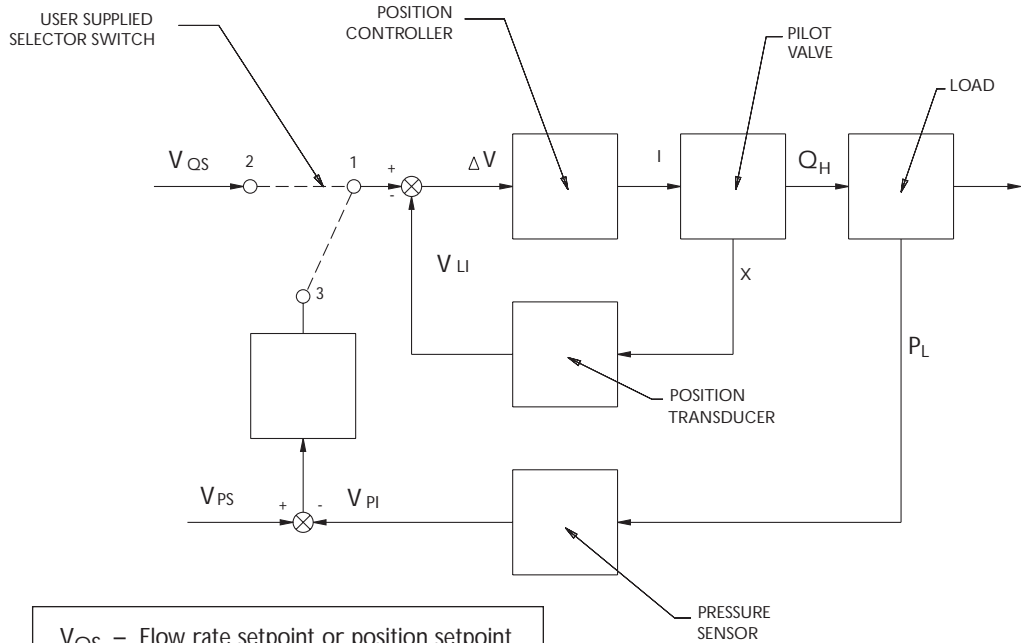

- V_{QS} – Flow rate setpoint or position setpoint
 - V_{LI} – Actual position value
 - V_{PS} – Pressure setpoint
 - V_{PI} – Actual pressure value*
 - X – Sliding spool displacement
 - P_L – Load pressure
- * can be tapped at the electrical connector for testing, monitoring, and recording purposes.

FLOW CONTROL – WITH SUPERIMPOSED PRESSURE LIMITING CONTROL

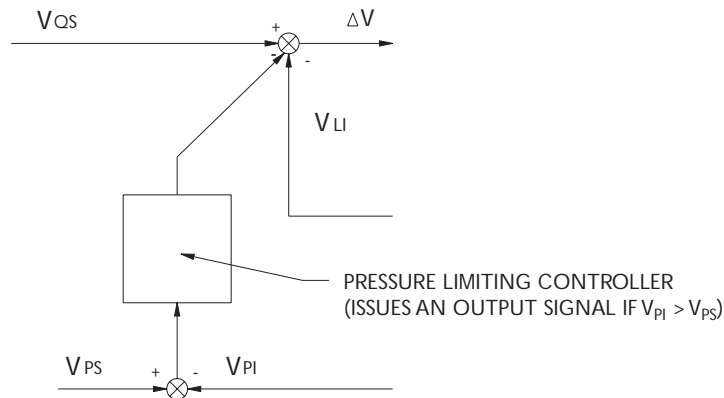

STANDARD ELECTRICAL CONFIGURATION

Valve in Main Flow Path

Flow control and change to pressure control

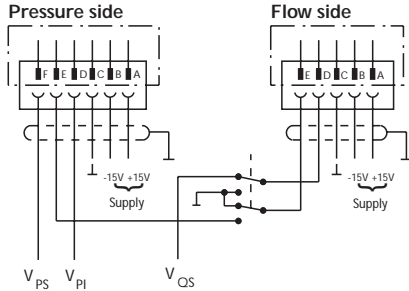

Valve in Bypass Flow Path

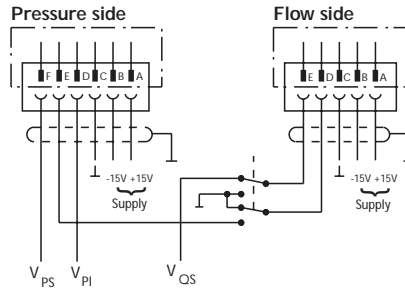

ELECTRICAL CONNECTION

Electrical characteristics

Supply Voltage:

$\pm 15\text{VDC}, \pm 3\%$

Current Consumption:

300 mA maximum

Input Impedance:

$> 50\text{ k}\Omega$

Flow Setpoint:*

$\pm 10\text{V}$ in main flow path

$+ 10\text{V}$ in bypass flow path

Pressure Setpoint:*

$+ 10\text{V}$

Actual Pressure Value:*

$- 10\text{V}$

* Typical values, alternative setpoints are available

Flow control with superimposed pressure limiting control

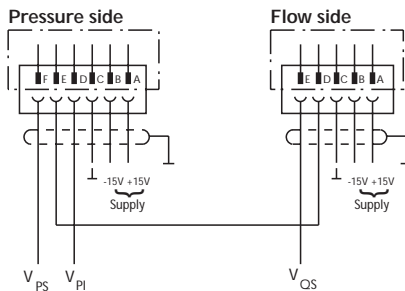
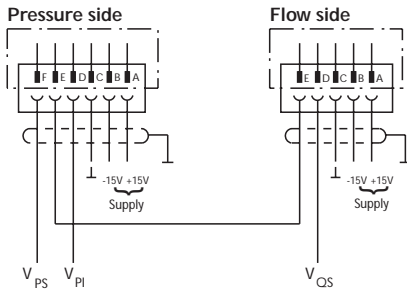

APPLICATION NOTES

The preferred applications for the 651 Series valves are velocity control systems and pressure or force control circuits. For increased accuracy, a velocity control loop can be formed by additional feedback of the load velocity using suitable electronic circuitry.

Since the pressure function operates on the closed-loop principle, optimization and matching of the pressure controller to the load is required. Consult the factory for further details.

TYPICAL HYDRAULIC SCHEMATIC

Valve in Main Flow Path

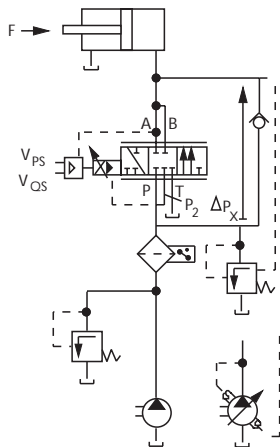

The valve operates as an electrically adjustable restrictor from P to A (P_2 to B), or from A to T and as an electrically adjustable pressure reducing valve.

Valve in Bypass Flow Path

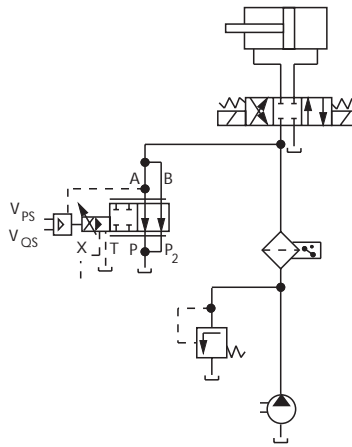

The valve operates as an electrically adjustable bypass restrictor and as an electrically adjustable pressure limiting valve.

651 SERIES PROPORTIONAL VALVES

AVAILABLE FLOW AND SPOOL CONFIGURATIONS

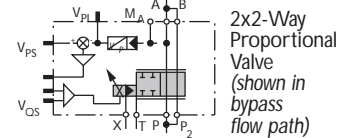
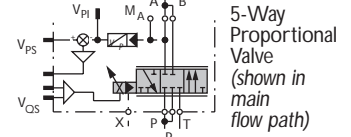
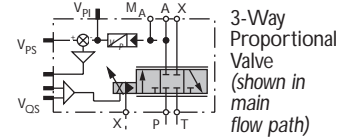
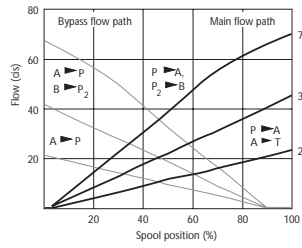
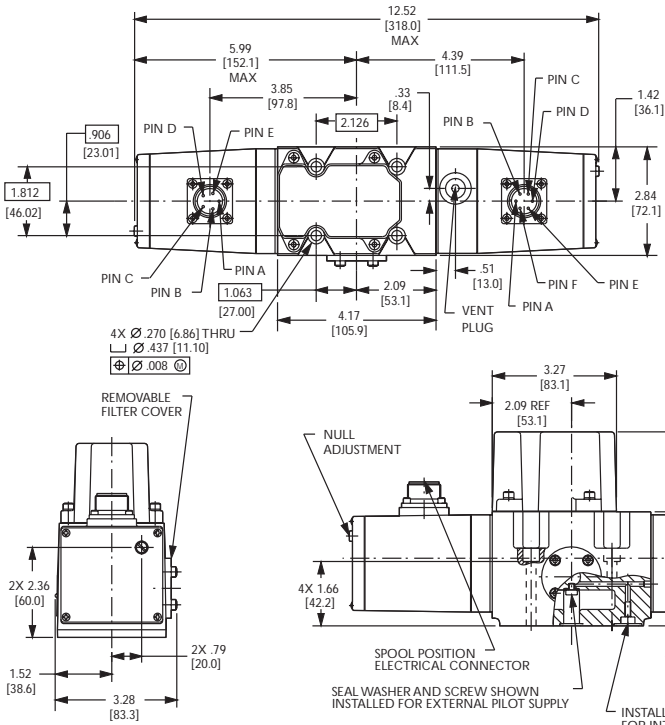

TYPICAL SUBPLATE MANIFOLD

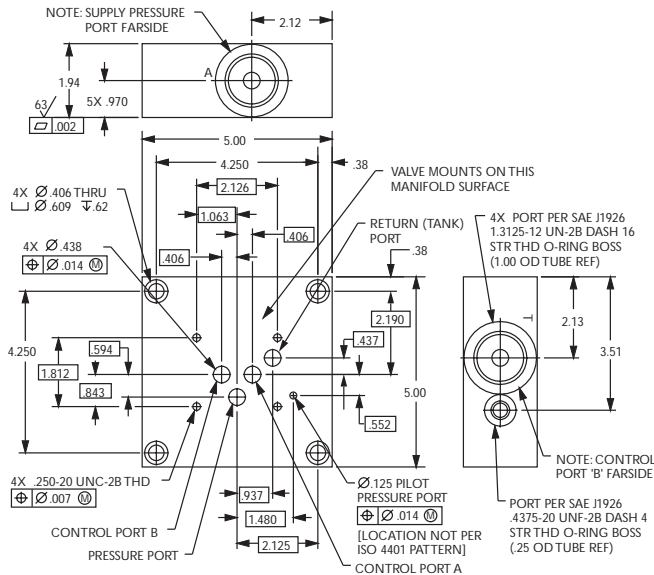

The products described herein are subject to change at any time without notice, including, but not limited to, product features, specifications, and designs.

ACCESSORIES

Flushing Block: P/N B67728-002

Mating Electrical Connectors:

Pressure side: P/N 49054F14S6S (MS3106F14S-6S)

Flow side: P/N 49054F14S5S (MS3106F14S-5S)

Suggested Mounting Bolts:

1/4 - 20 NC x 2 long Socket Head Cap Screw or M 6 x 50 Socket Head Cap Screw

Subplate:

for pressures to 5,000 psi (350 bar):

3 & 4-way, 4- or 5-port operation: P/N B52576AM1

2 x 2- or 5-way operation: P/N A96248-1

Filter: P/N A67999-100

NOTES

Valve Weight: 14 lb (6.4 kg)

P, T, A, & B Port O-Ring Size:

(5) 0.070 [1.8] section x 0.489 [12.4] I.D. (universal size - 014)

X and Y Port O-Ring Size:

(2) 0.070 [1.8] section x 0.614 [15.6] I.D. (universal size - 016)

Null Adjust: Flow out of port A will increase with clockwise rotation of null adjust potentiometer (4-turn potentiometer under screw plug).

Surface Finish: Surface to which valve is mounted requires $\sqrt{63}$ finish, flat within 0.001 [0.02] TIR.

MOOG

Industrial Controls Division

Moog Inc., East Aurora, NY 14052-0018

Telephone: 716/655-3000

Fax: 716/655-1803

Toll Free: 1-800-272-MOOG